

### Features and Benefits

- Conforms with ISO14443A<sup>(1)(3)</sup>
- Conforms with ISO14443B<sup>(2)</sup>
- Conforms with ISO15693<sup>(3)</sup>
- Programmable encoder and decoder
- Low external component count

### Applications

- Portable data terminals
- Access control readers
- Contact-less payment terminals
- Smart label printer

(1).Purchase of MLX90121s doesn't imply any grant of any ISO14443A license. Customers are advised to sign patent licensing agreements with all third parties, especially those companies listed in the introduction of the corresponding standard.

(2) RATP / Innovatron Technology

(3) Conformance with ISO/IEC15693 "long distance mode" (6.6kb/s ASK) and ISO/IEC14443A is limited to a temperature range from 0°C to 85°C.

### Ordering Information

Part No.	Temperature Suffix	Package Code	Option code
MLX90121	C (0°C to 70°C)	FR (Lead free SSOP20, 20 9 mils)	--
MLX90121	E (-40°C to 85°C)	FR (Lead free SSOP20, 2 09 mils)	--

## 1. Functional Diagram

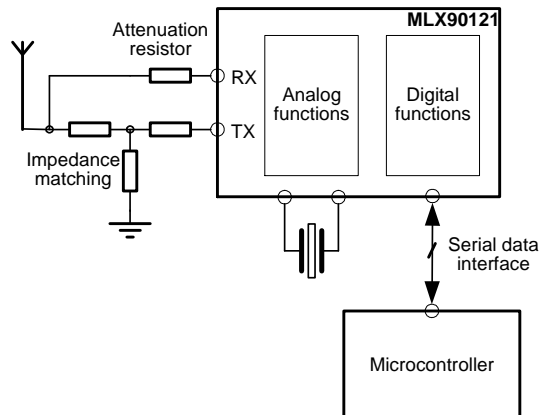

## 2. Description

The MLX90121 is an ISO compliant 13.56MHz RFID transceiver integrated circuit.

The main features include user selectable modulation depth in write mode, whereas single sub-carrier ASK, FSK and PSK modulations are recognized in the read mode.

The receiver is based on a diode envelope detector, followed by an IF filter and amplifier. A logarithmic amplifier is used for single sub-carrier ASK detection, ensuring fast and clean data recovery. The limiting output of the log amp is used for FSK and PSK recovery.

The transmitter uses a built in open drain output transistor, which can provide up to 250 milliwatts of RF power to a 50 ohms load with a 5 volts power supply using the recommended matching network. This is suitable for most short to mid range applications. A simplified antenna and matching network can be used, at the expense of a reduced reading range, for example in hand-held reader applications.

The chip is configured with a serial interface. A synchronization signal is available when the majority voting is used.

Digital part contains ASK, FSK (423 / 484kHz) and PSK (847kHz) decoders and a programmable encoder to facilitate data handling with a low cost microcontroller. The encoder can be programmed with 6 different patterns.

The chip can also be used as an analog front-end, in direct mode.

## TABLE OF CONTENTS

<b>FEATURES AND BENEFITS .....</b>	<b>1</b>
<b>APPLICATIONS.....</b>	<b>1</b>
<b>ORDERING INFORMATION.....</b>	<b>1</b>
<b>1. FUNCTIONAL DIAGRAM.....</b>	<b>1-1</b>
<b>2. DESCRIPTION.....</b>	<b>2-1</b>
<b>3. GLOSSARY OF TERMS .....</b>	<b>3</b>
<b>4. ABSOLUTE MAXIMUM RATINGS .....</b>	<b>3</b>
<b>5. MLX90121 ELECTRICAL SPECIFICATIONS .....</b>	<b>3</b>
<b>6. MLX90121 SPECIFIC SPECIFICATIONS.....</b>	<b>4</b>
<b>7. GENERAL DESCRIPTION .....</b>	<b>6</b>
<b>8. APPLICATIONS INFORMATION.....</b>	<b>7</b>
<b>9. BLOCK DIAGRAM .....</b>	<b>8</b>
<b>10. DIGITAL INTERFACE .....</b>	<b>8</b>
<b>11. OPERATING MODES.....</b>	<b>9</b>
11.1. DEFINITIONS .....	9
11.2. CONFIGURATION MODE .....	9
11.3. COMMUNICATION MODES .....	10
11.3.1. <i>Transmission</i> .....	10
11.3.2. <i>Reception</i> .....	14
11.4. POWER MODES.....	18
11.5. XBUF OUTPUT .....	19
<b>12. CONFIGURATION REGISTERS .....</b>	<b>20</b>
<b>13. CONFIGURATION REGISTERS: ISO CONFIGURATION EXAMPLES.....</b>	<b>22</b>
<b>14. STANDARD INFORMATION REGARDING MANUFACTURABILITY OF MELEXIS PRODUCTS WITH DIFFERENT SOLDERING PROCESSES .....</b>	<b>23</b>
<b>15. ESD PRECAUTIONS.....</b>	<b>23</b>
<b>16. PACKAGE INFORMATION.....</b>	<b>24</b>
<b>17. DISCLAIMER .....</b>	<b>26</b>

### 3. Glossary of Terms

RFID	Radio Frequency IDentification
ISO	International Organization for Standardization / International Electro-technical Commission.
ASK	Amplitude Shift Keying
FSK	Frequency Shift Keying
PSK	Phase Shift Keying

### 4. Absolute Maximum Ratings

Parameter	Symbol	Condition	Min	Max	Unit
Supply voltage ( $V_{DD}$ with respect to $V_{SS}$ )	$V_{DD}$	DC	-0.3	6	V
Input voltage on any pin (except TX)	$V_{in}$		-0.3	$V_{DD}+0.3$	V
Maximum power dissipation (without heat sink)	$P_{max}$			500	mW
Maximum junction temperature	$T_j$			+150	°C
Storage temperature	$T_{stor}$		-55	+150	°C

Exceeding the absolute maximum ratings may cause permanent damage. Exposure to absolute-maximum-rated conditions for extended periods may affect device reliability.

### 5. MLX90121 Electrical Specifications

$T_A = -40\text{ °C}$  to  $+85\text{ °C}$ , or  $0\text{ °C}$  to  $+70\text{ °C}$  according to the version,  $V_{DD} = 5\text{ Volts}$ , unless otherwise noted. On board resonator is used.

Parameter	Symbol	Test Conditions	Min	Typ	Max	Units
<b>General DC Parameters</b>						
Operating supply voltage range	$V_{DD}$	$V_{DD}$ with respect to $V_{SS}$	2.7	5	5.5	V
Standby current consumption	$I_{stb}$	$V_{DD} = 5.5\text{ V}$ - $T_A = +85\text{ °C}$ $T_A = +25\text{ °C}$		3 0.1	30 10	$\mu\text{A}$ $\mu\text{A}$
Idle mode current consumption	$I_{dle}$	$V_{DD} = 5.5\text{ V}$ - Analog section off $V_{DD} = 3\text{ V}$ , XBUF output disabled		3	5	mA
				1	3	mA
Transmit current	$I_{tr}$	50 Ohms load $V_{DD} = 3\text{ V}$		80	120	mA
				45	70	mA

### 6. MLX90121 Specific Specifications

DC Operating Parameters  $T_A = -40^{\circ}\text{C}$  to  $85^{\circ}\text{C}$ , or  $0^{\circ}\text{C}$  to  $+70^{\circ}\text{C}$  according to the version,  $V_{DD} = 5\text{V}$  (unless otherwise specified)

Parameter	Symbol	Test Conditions	Min	Typ	Max	Units
<b>Transmitter specifications</b>						
Peak voltage applied on drain of output transistor					32	V
Output transistor power dissipation		With heat sink			600	mW
Output transistor ON resistance		$I_d = 50\text{ mA}$		2	5	$\Omega$
Output power for five volts operation		See note 1		250		mW
Amplitude modulation depth adjustment range, in 10% mode, with external resistor connected between RMOD pin and ground.		See note 1	0		90	%
Amplitude modulation depth in 10% mode with nominal external resistor ( $10\Omega$ )		See note 1	8	10	14	%
Minimum depth for 100% ASK		See note 1	40			dB
Rise time for 100% ASK		50 Ohms load - 5% to 60%		0.2	0.4	$\mu\text{s}$
		50 Ohms load - 5% to 90%		0.3	1.5	$\mu\text{s}$
Fall time for 100% ASK		50 Ohms load - 100% to 5%		0.6		$\mu\text{s}$
Rise and fall time for 10% modulation depth (nominal external resistor used)		50 Ohms load		0.2		$\mu\text{s}$
<b>Receiver specifications</b>						
Small signal input impedance (RX)				100		$k\Omega$
Input RF voltage range (RX - $V_{SS}$ )		With $4.7k\Omega$ series external resistor		2	3	$V_{pp}$
Receiver sensitivity		See note 2	-35	-45		dBm
FSK IF filter cut off points				200-1400		kHz
Gain, in FSK mode (FM output)				120		dB
Gain, in ASK mode (AM output)				80		dB

<b>Serial link and digital I/O</b>						
Output current drive	$I_{ol}$	$V_{ol} \leq 0.4$ Volt	4			mA
Output voltage low	$V_{ol}$	$I_{ol\ max}=4$ mA	0	0.2	0.4	V
Output voltage high	$V_{oh}$	$I_{oh\ max}=4$ mA	4.6	4.8	5	V
Input voltage high	$V_{ih}$		$0.7 * V_{DD}$		$V_{DD} + 0.3$	V
Input voltage low	$V_{il}$		-0.3		$0.3 * V_{DD}$	V
CK pulse	$T_{CK}$	"0" level pulse or "1" level pulse	500			ns
General setup time	$T_s$		60			ns
General hold time	$T_h$		60			ns
Pulse time between successive registers writing	$T_{mw}$		5			$\mu$ s
<b>Crystal Oscillator</b>						
Frequency range	$F_{xtal}$	ISO compliant applications		13.56		MHz
Start-up time	$T_{start}$			2	5	ms
Xtal series resistance				50	100	$\Omega$
<b>External clock signal specifications</b>						
Min sine wave amplitude, AC coupled Input on pin XTAL2		see note 3	1		$V_{DD}$	$V_{PP}$
Min sine wave amplitude, DC coupled Input on pin XTAL2		Input has to be centered around $V_{DD}/2$	1		$V_{DD}$	$V_{PP}$
<b>XBUF output specifications</b>						
XBUF Low Level ( $C_{ol}$ )		1K load resistor		0.1		V
XBUF High Level ( $C_{oh}$ )		1K load resistor		4.8		V
Rise and fall times (10%-90%)		1K load resistor//12pF		3		ns

### Notes

- Parameter measured using recommended output matching network.
- This parameter is measured using a base band signal for all specified modulation modes. The measurement is made at the DOUT output with the input diode detector bypassed.
- The external clock symmetry is of paramount importance. It has a direct influence on the transmitter output power. When using a sine wave as external clock input, it must not show visible distortion. In case a square wave is used, its duty cycle has to be equal to 50%.

## **7. General Description**

### **Power supply**

The 90121 requires a nominal 3 or 5 volts external power supply. Operation is guaranteed between 2.7 and 5.5 Volts. The current drain depends on the antenna impedance and the output matching network configuration. Care must be taken about the power supply: power supply ripple and noise will severely degrade the overall system performance.

### **Transmitter**

The output transistor is a low Ron MOSFET. The drain is directly accessible on the TX pin. A recommended application schematic optimized to drive a resistive fifty ohms antenna with a five volts power supply is provided as a part of this specification. A simple resonant circuit or/and a simpler matching network can be connected to the output. In that case, the general performance and harmonic suppression will be reduced.

100 % modulation is achieved by means of gating the square wave drive of the output transistor.

A variable modulation depth is obtained by means of switching a resistor in series with the output transistors' source connection. An external resistor provides the default modulation depth setting. Increasing this external resistor will increase the modulation depth.

### **Receiver**

The receiver input is typically connected to the antenna through an external resistor. The modulation from the tag is then recovered by means of a diode envelope detector.

### **FSK and PSK recovery**

The demodulated input signal is amplified and band pass filtered. The signal is then hard limited by a logarithmic amplifier, and fed to the digital section. PSK decoded, FSK decoded or a direct FSK signal can be used for further decoding.

### **ASK recovery**

For ASK recovery, the high pass sections of the band pass filters are removed, to avoid falling edge degradation by the filter settling time. The signal is DC coupled and fed to the input of the logarithmic amplifier. The logarithmic amplifier works as a high gain amplifier and at the same time it generates the envelope of the ASK signal. The demodulated output from the log amp is then

fed to a comparator. To avoid signal degradation, the time constant of the comparator has to be switched from fast response during acquisition to a slow time constant during the tags response. This is done by switching the CK signal at the beginning of the response of the tag. The recovered data stream is fed to the digital section for further processing.

### **Majority Voting**

Both FSK/PSK or ASK can use the Majority Voting function that will filter for noise and jitter, that will correct distorted signals and will hence improve performance.

### **Reference clock and internal oscillator**

The reference clock may be obtained externally by applying a suitable clock signal to the XTAL1 pin. A sine wave centered at VCC/2 or a CMOS logic compatible signal is an acceptable external system clock. The built-in reference oscillator will work either with a quartz crystal or a ceramic resonator. The nominal system clock frequency is 13.56 MHz.

### **Reset defaults and power management**

After a power on reset has been performed, the device is put in its default configuration. There are three power modes available. In the transmission mode, the device is fully powered. In the idle mode, only the reference oscillator is running. This allows for a fast start up. In the power down mode, the device internal bias system is completely switched off, offering essentially a zero state.

### **Serial communication interface**

The communication interface normally uses 6 wires:

- CK: serial clock input
- DIN: data input
- DOUT: data output
- DSYNC: synchronization output for DOUT
- MODE: configuration or communication selection input
- RTB: reception or transmission selection input.

## 8. Applications Information

This schematic has been optimized to drive a fifty ohms resistive antenna, using a five volts power supply.

### Functional description

The transmitter output TX is connected to the supply by means of a choke L3. C3 is added to avoid a high dV/dt at the TX output in case of a sudden interruption of the current in the choke. C3 is chosen high enough to protect the chip, but low enough to keep the resonance of L3-C3 well above 13.56 MHz.

The transmitter signal is coupled with DC blocking capacitor C2 to the antenna matching network, which is a T network made up by L2, CV1 and L1. CV1 allows a proper matching between the 50Ohm antenna and the output impedance of the transmitter stage.

The receiver part of the chip gets its signal directly from the antenna by means of R1. It limits the voltage swing at the RX pin to a level in between the supplies.

One should take care to properly decouple the power supplies of the chip. Especially the Vdd1 supply which is used for the transmitter output. Any amplitude noise on that supply is AM modulated on the carrier and will hence be perceived as noise by the receiver part. The same holds for any phase noise that gets introduced into the quartz oscillator.

For the signal that goes to- and from the microcontroller: one should take care to keep them as far as possible from the analog parts and the quartz oscillator. To do a first evaluation, it is highly recommended to use the MLX90121 evaluation board that can be ordered from Melexis. The clock for the microcontroller can also be derived from the XBUF pin. This pin provides a 13.56MHz buffered clock or 13.56MHz divided by 2.

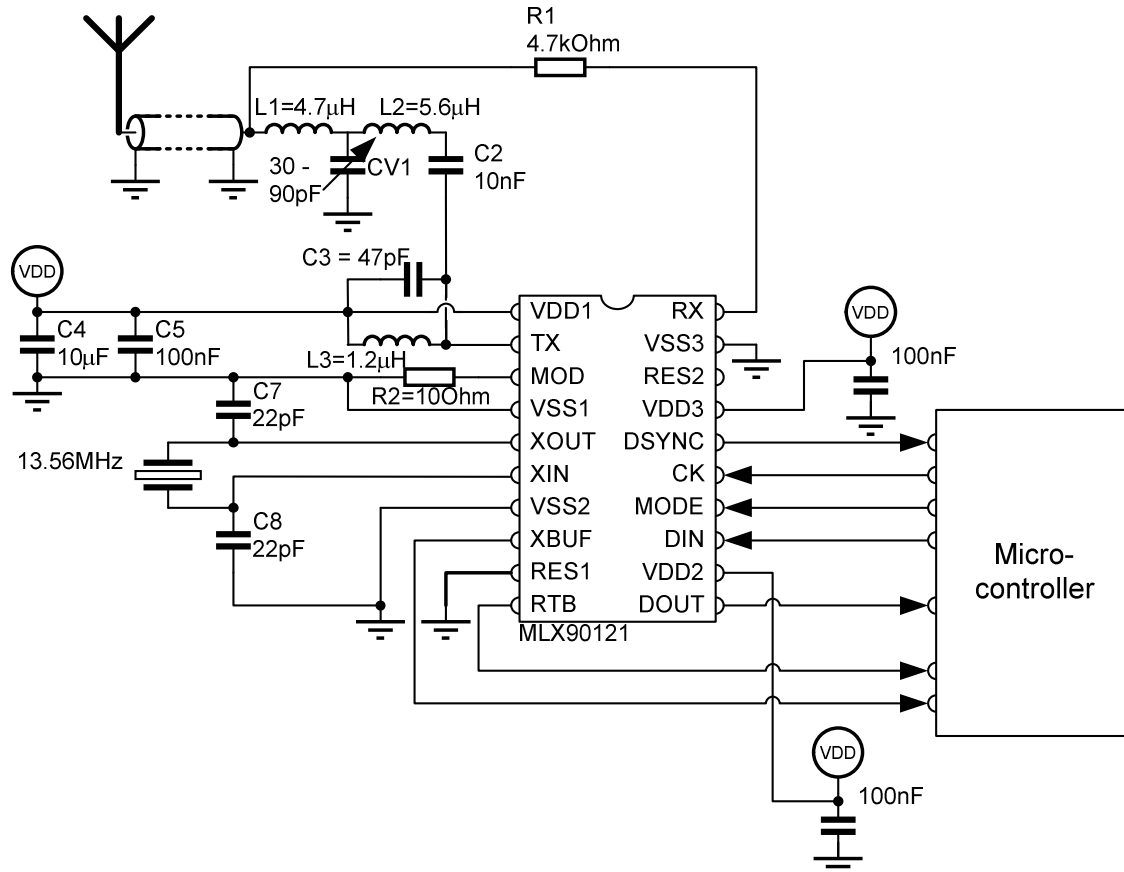

## 9. Block Diagram

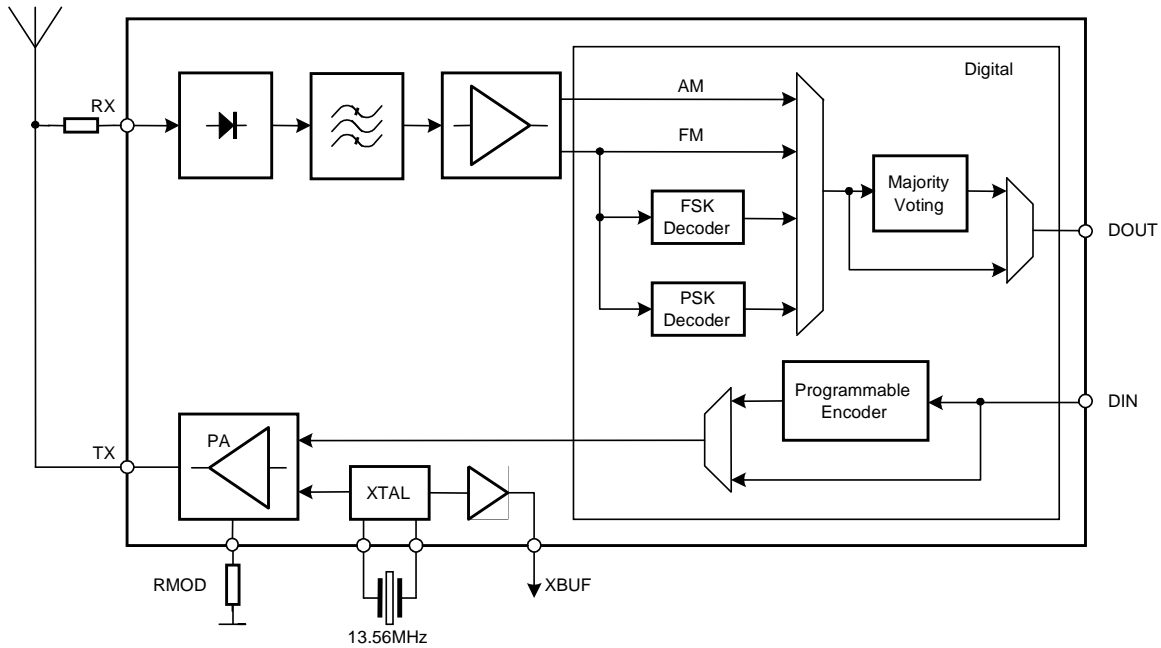

## 10. Digital Interface

The MLX90121 is driven by four signals: MODE and RTB pins are used to select the operating mode and DIN and CK pins are used to configure the chip and to transmit data.

The MLX90121 has two signal outputs. DOUT contains the decoded response of the transponder and DSYNC is used as a synchronization output by the microcontroller.

Pin Name	I/O	Function
MODE	I	0 = Configuration Mode, 1 = Communication Mode
RTB	I	0 = Transmission Mode, 1 = Reception Mode
DIN	I	Data Input for Transmission or Configuration
CK	I	Clock and Trigger
DOUT	O	Data Output from Reception or Configuration
DSYNC	O	Data Synchronization Clock for Transmission or Reception

### Function Summary

MODE	RTB	Function
0	0	Configuration
1	0	Transmission
0	1	Reserved (*)
1	1	Reception

(\*) the reserved mode is for manufacturing purpose only and should not be applied by the user.



## 11. Operating Modes

### 11.1. Definitions

There are two main operating modes:

- MODE = 0 : Configuration Mode
- MODE = 1 : Communication Mode

The configuration mode allows writing in the configuration registers. It will configure all parameters in the transceiver.

The communication mode allows communicating with a transponder. Different options are available:

- Direct transmission: The transmission protocol is handled by an external microcontroller.
- Hardware transmission: The low level protocol is handled by an internal programmable encoder. It allows using a low cost microcontroller.
- Direct reception: The reception protocol is handled by an external microcontroller.
- Hardware reception: FSK/PSK decoders and Majority Voting can be enabled to allow using a low cost microcontroller.

### 11.2. Configuration Mode

#### Registers Addresses

For configuration purposes, users have access to 13 eight bit registers, which can be addressed using a 4 bit address.

Address	Register name
0	AnalogConfig
1	PowerState
2	Reserved (*)
3	DigitalConfig
4	EncoderSym0
5	EncoderSym1
6	EncoderSym2
7	EncoderSym3
8	EncoderSym4
9	EncoderSym5
10	EncoderTimeRef
11	DecoderTimeRef
12	LTC

(\*) the reserved register is for manufacturing purpose only and should not be used.

#### Write Configuration Registers

First the MODE line is asserted low to enable the configuration mode. Then data is fed serially into the chip with the CK and DIN lines. Data on the DIN line is read on the rising edge of CK. The first four bits on DIN are the register address and the eight following bits are the data. Address and data fields are written MSB (Most Significant Bit) first.

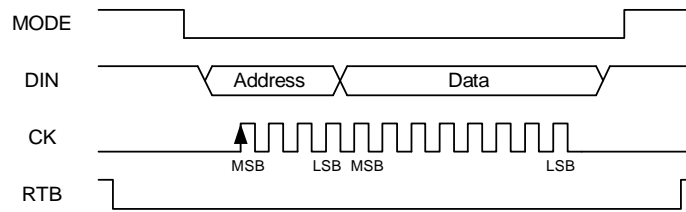

After sending address and data, the MODE line is asserted high and the chip is ready to receive the next register configuration.

Signal	Assign
MODE	0
RTB	0
DIN	4-bit Address + 8-bit Data
CK	12 clock pulses
DOUT	x
DSYNC	x

### Notes

1. If a register does not contain eight bits, write '0' in the unused bit.
2. When MODE is asserted high, the chip is in communication mode. If the encoder is disabled (by default), DIN has to be kept at '1' to avoid any modulation on the antenna.
3. In case of successive registers writings, it is mandatory to have MODE asserted high for at least  $T_{mw} = 5\mu s$  in between each access, as shown in the following diagram.

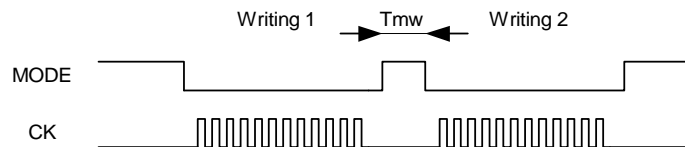

## 11.3. Communication Modes

### 11.3.1. Transmission

#### 11.3.1.a. Analog Setup

For the transmission, the modulation depth has to be chosen. This is done by the TModIndex bit of the AnalogConfig register, which selects the modulation index: 10% or 100%.

The modulation index can be further tuned by means of the external RMOD resistor.

### 11.3.1.b. Direct Transmission

Before analog processing, data transmission can be either direct or pre-processed by means of hardware accelerators. Direct transmission can be performed with the following setup:

Signal	Assign
MODE	1
RTB	0
DIN	Data to transmit
CK	0
OUT	x
DSYNC	x

Data has to be transmitted in real time by the microcontroller on DIN input. The modulation is done when DIN is asserted low, so by default DIN has to be asserted high. If a configuration register has to be written, keep DIN high when MODE is asserted low. In configuration mode, the field is held without modulation independently of DIN.

### 11.3.1.c. Hardware Encoding Transmission

This programmable encoder allows predefining six different patterns of 8 bits. The encoder is selected by setting the bit EncoderEn in the DigitalConfig register.

#### Symbol Setup

The six symbols are called EncoderSym0 to EncoderSym5. There is a seventh symbol which is hard-coded to 0xFF (11111111).

A symbol is built with 8 bits as shown in the following figure.

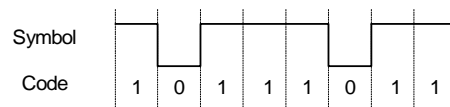

#### ISO Examples

The ISO15693 protocol, mode 1 out of 4, is implemented using six symbols as shown in the following table. Start of frame (SOF), end of frame (EOF) and pulses are all encoded using one symbol.

ISO15693 (1 out of 4)		
Symbol	Name	Code
Sym0	Pulse1	10111111
Sym1	Pulse2	11101111
Sym2	Pulse3	11111011
Sym3	Pulse4	11111110
Sym4	SOF	01111011
Sym5	EOF	11011111

The ISO15693 protocol, mode 1 out of 256, is implemented using three symbols. Start of frame (SOF), end of frame (EOF) and pulses encoding result of the combination of these three symbols.

ISO15693 (1 out of 256)	
Symbol	Code
Sym0	11111111
Sym1	11110000
Sym2	00001111

ISO15693 (1 out of 256)	
Name	Combination
SOF	Sym2+2*Sym0+Sym1
EOF	Sym0+Sym2
Pulse 1 to 256	255*Sym0+Sym1

**Note**

- The position of the symbol Sym1 encodes pulses from 1 to 256. For example: Pulse1 = Sym1 + 255\*Sym0 and Pulse45 = 44\*Sym0 + Sym1 + 211\*Sym0.

The ISO14443 -A protocol is implemented using three symbols, according to the ISO specification.

ISO14443-A		
Symbol	Name	Code
Sym0	X	11110011
Sym1	Y	11111111
Sym2	Z	00111111

The ISO14443 -B protocol is implemented with only two symbols. This allows fast addressing with only one CK pulse.

ISO14443-B		
Symbol	Name	Code
Sym0	L	00000000
Sym1	H	11111111

**Time Reference Setup**

The time reference is defined in the EncoderTimeRef register. The time reference contains the value of one bit time. Hence  $Symbol\_Time = 8 * Bit\_Time$

The bit time is defined by the EncTimeRef parameter. EncTimeRef is an integer value, it is calculated as follows:

$$EncTimeRef = \left( \frac{Bit\_Time}{1/3.39Mhz} \right) - 1$$

EncTimeRef is coded on 5 bits. This means that Bit\_Time\_max = 9.44µs and Symbol\_Time\_max = 75.52µs.

### ISO Examples

Norm	Symbol Time	Bit Time	EncTimeRef
ISO15693 (1 out of 4)	75.52 $\mu$ s	9.44 $\mu$ s	0x1F (11111)
ISO15693 (1 out of 256)	18.88 $\mu$ s	2.36 $\mu$ s	0x07 (00111)
ISO14443	9.44 $\mu$ s	1.18 $\mu$ s	0x03 (00011)

### Symbol Transmission

CK and DIN inputs are used to transmit symbols. On each rising edge of the CK signal, DIN is sampled to encode the address of the corresponding symbol. This means that each address of the seven available symbols can be encoded with a maximum of three bits (meaning three CK pulses). To reduce the usage of the microcontroller for fast protocol, Sym0 and Sym1 can be transmitted with only one bit and, Sym2 and Sym3 with two bits, as shown in the following table.

Symbol	First Symbol 3 bits are needed to initiate Transmission	Subsequent Symbols Reduced encoding possible (minimum 1 bit)
Sym0	000	0
Sym1	001	1
Sym2	010	10
Sym3	011	11
Sym4	100	100
Sym5	101	101
Sym6 (*)	110	110

(\*) Symbol 6 is hard coded to 0xFF (11111111).

To initiate a transmission, it is necessary to send the first symbol with three CK pulses to initialize the communication. On every rising edge of DSYNC, the following symbol is sent. To complete the transmission, no more CK pulse should be sent after EOF symbol.

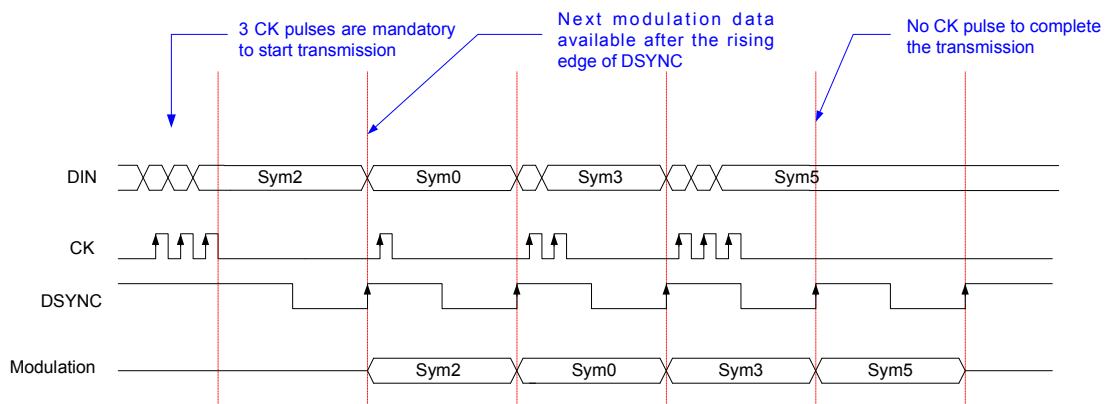

Signal	Assign
MODE	1
RTB	0
DIN	Symbol to transmit
CK	Clock
DOUT	x
DSYNC	Symbol Synchronization

### 11.3.2. Reception

#### 11.3.2.a. Analog Setup

For a proper reception, the analog chain has to be configured according to the following parameters in the AnalogConfig register:

- ByPassAll: It bypasses the analog filters in the analog chain. Must be enabled for AM reception.
- RSub-carrier: It selects the reception sub-carrier frequency – See table.

RSub-carrier	Sub-carrier
0	423 / 484 kHz
1	847 kHz

#### ISO Examples

Standard	ByPassAll	RSub-carrier
ISO15693-Single Sub-carrier	1	0
ISO15693-Dual Sub-carrier	0	0
ISO14443-A	1	1
ISO14443-B	0	1

### 11.3.2.b. Direct Reception

After analog processing, data reception can be either direct or pre-processed by hardware accelerators, according to the configuration of the SelDOUT parameter in the DigitalConfig register.

SelDout	Output	Hardware	ISO Standard
00	AM (direct)	--	ISO15693-Single Sub-carrier and ISO14443 - A
01	FM (direct)	--	--
10	FSK (423/484 kHz)	FSK decoder	ISO15693-Dual Sub-carrier
11	PSK (847 kHz)	PSK decoder	ISO14443-B

#### Note

- The output phase of PSK decoder is either normal or inverted.

Direct reception is achieved with the following setup.

Signal	Assign
MODE	1
RTB	1
DIN	1
CK	0
DOUT	Received data
DSYNC	x

### 11.3.2.c. Reception with Majority Voting (MV)

Majority voting allows to:

- Filter noisy signal,
- Compensate for jitter,
- Correct distorted signals.

At the beginning of the time slot (MVTime), an up / down counter is reset. When the input signal is asserted high, it is counting up and when the input signal is asserted low, it is counting down. At the end of time slot, the counter value is checked and the output value is set accordingly (low if counter is negative; high if counter is positive).

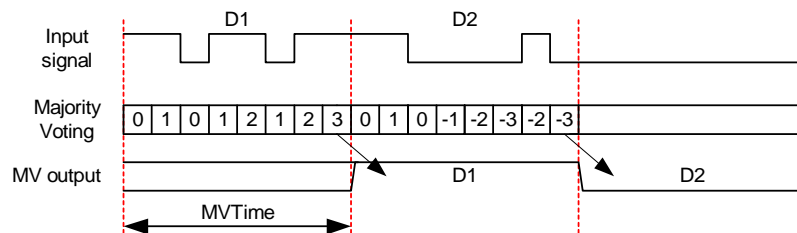

#### Majority Voting Setup

The following parameters in the DigitalConfig register have to be set when using majority voting.

- MVEn: it enables the majority voting function.
- DecTimeRef: it defines the duration of the time slot (MVTime)

$$DecTimeRef = \left( \frac{MVTime}{1/6.78MHz} \right) - 1$$

$$MVTime_{max} = 37.76\mu s$$

**ISO examples**

Norm	MVTime	DecTimeRef
ISO15693 Single Sub-carrier – high baud rate	18.88μs (half bit)	127
ISO15693 Dual Sub-carrier – high baud rate	18.73μs (half bit)	126
ISO15693 Single Sub-carrier – low baud rate	37.6μs (quarter bit)	255
ISO15693 Dual Sub-carrier – low baud rate	37.46μs (quarter bit)	253
ISO1444-A	4.72μs (half bit)	31
ISO1444-B	9.44μs (full bit)	63

**Note**

- For Manchester coding, majority voting is on half bit portions only.

In addition, the MVMode parameter in the DigitalConfig register allows giving more weight to low input levels.

**Note**

- It is highly recommended to use Majority Voting for all ISO standard configurations.

**MV Reception**

To start a reception with majority voting function, assert CK high at the beginning of the response. Then take data on every falling edge of DSYNC. Reception is stopped by asserting CK low on the last rising edge of DSYNC. Data output are delayed by DecTimeRef (see next figure).

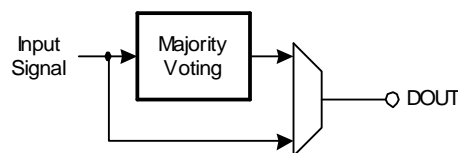
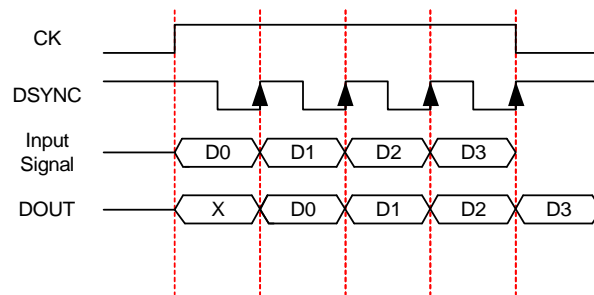



### Example in ISO1569-Dual Sub-carrier

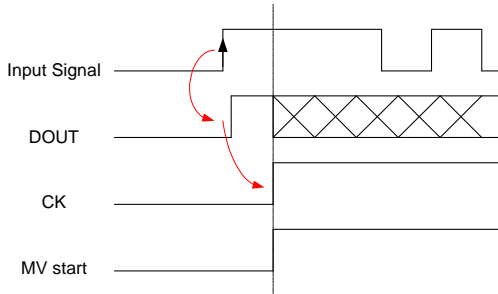

Standard	Reference for input signal
ISO15693-Single Sub-carrier	Rising edge
ISO15693-Dual Sub-carrier	Rising edge
ISO14443-A	Rising edge
ISO14443-B	Rising / Falling edge

### Data Slicer

LTC is an internal signal which controls the time constant of the comparator. This signal is switched to ensure a proper decoding in ASK modes in order to improve the reading performances.

LTC is controlled according to the following parameters in the LTC register:

- LTCEn: it enables the LTC circuit.
- LTCDelay: delay to switch the time constant (see next table).

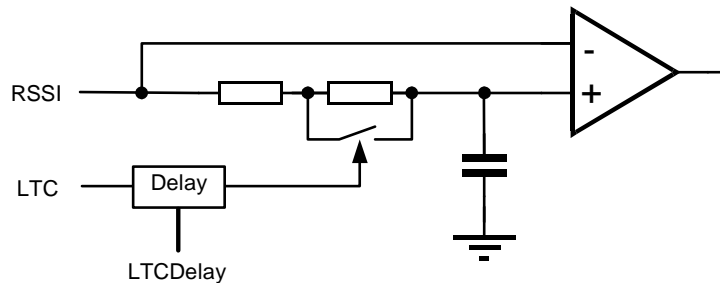

### Recommended delay for ISO standard

Standard	DelayTime	LTCDelay
ISO15693-Single Sub-carrier	4.72 $\mu$ s	0x1F
ISO14443-A	1.47 $\mu$ s	0x09

### Example in ISO15693-Single Sub-carrier

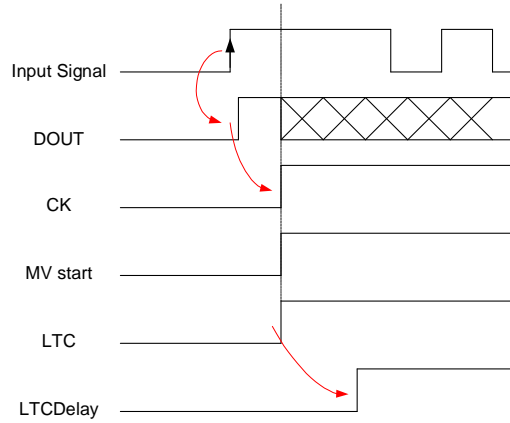

### 11.4. Power Modes

This chip has three power modes. To select one of these modes write the PowerState parameter in the PowerState register.

PowerState	Power Mode	Symbol
00	Low Power	I <sub>idle</sub>
01	Transmitter On	I <sub>tr</sub>
11	Power Down	I <sub>stb</sub>

#### Power Down

If the Power Down mode is selected, the crystal oscillator will be turned off. Therefore, it will be impossible to write the PowerState register to wake up the chip. To wake up the chip, it is necessary to send a falling edge on CK when DIN is low. During Power Down mode, keep DIN high to avoid glitches on CK.

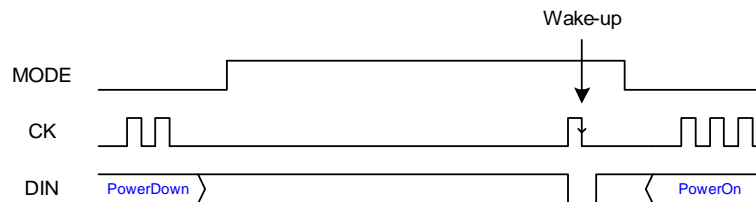

#### Notes

- After a wake-up, the chip has to be set in Transmitter On or Low Power mode by updating the PowerState register, after T<sub>start</sub>.

#### Low Power

The oscillator is still on but all analog circuitry is off.

### **11.5. XBUF Output**

The XBUF pin can be used to clock a device or a microcontroller. By default the output is enabled with a frequency of 6.78MHz. The frequency can be doubled to 13.56MHz by setting the bit XBUFSel. When the output is not used, it is recommended to disable the clock by setting the bit XBUFE<sub>n</sub>B.

### 12. Configuration Registers

The following tables explain the meaning of the bit configurations in the 13 registers.

Register : AnalogConfig			
Address : 0			
Bit	Default	Name	Function
7	0	XBUFSel	XBUF frequency selection (0 = 6.78MHz, 1 = 13.56MHz )
6	0	XBUFEb	XBUF Enable (0= Enabled, 1 = Disabled)
5	0	TModIndex	Transmission Modulation Index (0 = 100%, 1= 10%)
4	0	RSub-carrier	Reception Sub-carrier (0 = 450K , 1 = 847K) – See notes
3	0	Reserved	Do not use – Should always be configured at 0
2	0	ByPassAll	Bypass analog chain (0= Connected, 1 = Bypassed) – See notes
1:0	0	Reserved	Do not use - Should always be configured at 11

#### Notes

ByPassAll	Demodulation
0	FSK / PSK
1	ASK

RSub-carrier	Sub-carrier frequency
0	423 / 484 kHz
1	847 kHz

Register : PowerState			
Address : 1			
Bit	Default	Name	Function
7:2	0	Reserved	Do not use
1:0	0	PowerState	Chip Power State – See notes

#### Notes

Power State [1:0]		Mode
0	0	Idle (oscillator on)
0	1	Transmitter On
1	0	Unused
1	1	Power Down (oscillator off)

Register : Reserved			
Address : 2			
Bit	Default	Name	Function
7:0	0	Reserved	Do not use

Register : DigitalConfig			
Address : 3			
Bit	Default	Name	Function
7:6	0	--	Unused
5	0	Reserved	Do not use
4	0	MVMode	Majority Voting Mode (0 = other, 1 = ISO14443A)
3	0	MVEn	Majority Voting Enable (0=Disabled, 1 = Enabled)
2:1	0	SelDout	Reception Output Selection (see table)
0	0	EncoderEn	Hardware Encoder Enable (0=Disabled, 1 = Enabled)

### Notes

SelDout	Output
00	AM (DATA): '1' = sub carrier ; '0' = no sub carrier
01	FM (LIMITER): rough digital signal
10	FSK decoded: '1' when f = 423kHz, '0' when f = 484kHz
11	PSK decoded

Register : EncoderSym			
Address : 4 to 9			
Bit	Default	Name	Function
7:0	0	EncoderSym0	Encoder Symbol 0
7:0	0	EncoderSym1	Encoder Symbol 1
7:0	0	EncoderSym2	Encoder Symbol 2
7:0	0	EncoderSym3	Encoder Symbol 3
7:0	0	EncoderSym4	Encoder Symbol 4
7:0	0	EncoderSym5	Encoder Symbol 5

### Notes

- Symbol 6 is hard-coded to 0xFF (11111111).

Register : EncoderTimeRef			
Address : A			
Bit	Default	Name	Function
7:5	0	--	Unused
4:0	0	EncTimeRef	Encoder Time Reference

Register : DecoderTimeRef			
Address : B			
Bit	Default	Name	Function
7:0	0	DecTimeRef	Decoder Time Reference

Register : LTC			
Address : C			
Bit	Default	Name	Function
7:6	0	--	Unused
5:1	0	LTCDelay	LTC Delay
0	0	LTCEn	LTC Enable (0=Disabled, 1 = Enabled)

### 13. Configuration Registers: ISO Configuration Examples

Address	Register	Norm	ISO15693		ISO14443	
		Register	ASK	FSK	A	B
			High Baud Rate 100% modulation	High Baud Rate 10% modulation		
0	AnalogConfig		47	63	57	73
1	PowerState*		01	01	01	01
2	Reserved		00	00	00	00
3	DigitalConfig		09	0D	19	0F
4	EncoderSym0		BF	BF	F3	00
5	EncoderSym1		EF	EF	FF	FF
6	EncoderSym2		FB	FB	3F	00
7	EncoderSym3		FE	FE	00	00
8	EncoderSym4		7B	7B	00	00
9	EncoderSym5		DF	DF	00	00
10	EncoderTimeRef		1F	1F	03	03
11	DecoderTimeRef		7F	7E	1F	3F
12	LTC		3F	00	13	00

#### Notes

- All values are in hexadecimal notation.
- Transmitter is switched on.

## **14. Standard information regarding manufacturability of Melexis products with different soldering processes**

Our products are classified and qualified regarding soldering technology, solderability and moisture sensitivity level according to following test methods:

### **Reflow Soldering SMD's (Surface Mount Devices)**

- IPC/JEDEC J-STD-020  
Moisture/Reflow Sensitivity Classification for Nonhermetic Solid State Surface Mount Devices (classification reflow profiles according to table 5-2)
- EIA/JEDEC JESD22-A113  
Preconditioning of Nonhermetic Surface Mount Devices Prior to Reliability Testing (reflow profiles according to table 2)

### **Wave Soldering SMD's (Surface Mount Devices) and THD's (Through Hole Devices)**

- EN60749-20  
Resistance of plastic- encapsulated SMD's to combined effect of moisture and soldering heat
- EIA/JEDEC JESD22-B106 and EN60749-15  
Resistance to soldering temperature for through-hole mounted devices

### **Iron Soldering THD's (Through Hole Devices)**

- EN60749-15  
Resistance to soldering temperature for through-hole mounted devices

### **Solderability SMD's (Surface Mount Devices) and THD's (Through Hole Devices)**

- EIA/JEDEC JESD22-B102 and EN60749-21  
Solderability

For all soldering technologies deviating from above mentioned standard conditions (regarding peak temperature, temperature gradient, temperature profile etc) additional classification and qualification tests have to be agreed upon with Melexis.

The application of Wave Soldering for SMD's is allowed only after consulting Melexis regarding assurance of adhesive strength between device and board.

Melexis is contributing to global environmental conservation by promoting **lead free** solutions. For more information on qualifications of **RoHS** compliant products (RoHS = European directive on the Restriction Of the use of certain Hazardous Substances) please visit the quality page on our website: <http://www.melexis.com/quality.asp>.

## **15. ESD Precautions**

Electronic semiconductor products are sensitive to Electro Static Discharge (ESD). Always observe Electro Static Discharge control procedures whenever handling semiconductor products.

### 16. Package Information

The device is packaged in a 20 pin lead free SSOP package.

Pin #	Symbol	Pin Type	Description
1	VDD1	Supply	Transmitter power supply
2	TX	Analog	Output transistor drain connection
3	MOD	Analog	External resistor to set modulation depth
4	VSS1	Supply	Transmitter section ground
5	XOUT	Dig-Out	Output of crystal resonator
6	XIN	Dig-In	Input of crystal resonator and external system clock input
7	VSS2	Supply	Digital section ground
8	XBUF	Dig-Out	Buffered output of crystal oscillator
9	RES1	Reserved	Should be grounded for normal operation
10	RTB	Dig-In	Receive/Transmit selection
11	DOUT	Dig-Out	Data output
12	VDD2	Supply	Digital section power supply
13	DIN	Dig-In	Data input for registers or modulation
14	MODE	Dig-In	Configuration/Communication selection
15	CK	Dig-In	Serial clock input
16	DSYNC	Dig-Out	Data synchronization output
17	VDD3	Supply	Receiver section power supply
18	RES2	Reserved	Should be left unconnected for normal operation
19	VSS3	Supply	Receiver section ground
20	RX	Ana-In	Receiver input

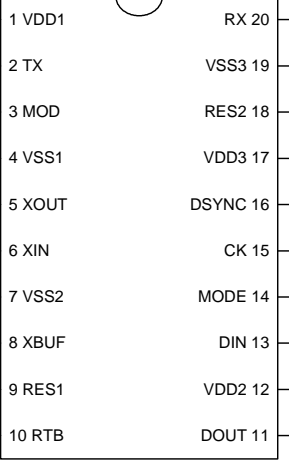

Moisture Sensitivity Level is MSL3, according as per IPC/JEDEC J-STD-20.

The mechanical dimensions of this package are depicted on the following page.



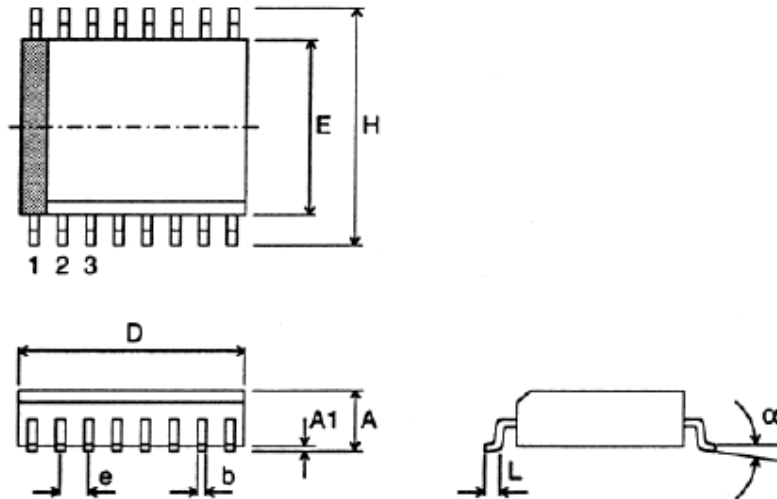

**Shrink Small Outline Package (SSOP)**

SSOP 20, 24, 28

Package type		D	E	H	A	A 1	e	b	L	$\alpha$	Package Code
SSOP 20	min	6.60	5.00	7.40		0.05		0.22	0.63	0°	FR20
	max	7.50	5.60	8.20	2.13	0.25	0.65	0.38	1.03	8°	
SSOP 24	min	7.90	5.00	7.40		0.05		0.22	0.63	0°	FR24
	max	8.50	5.60	8.20	2.13	0.25	0.65	0.38	1.03	8°	
SSOP 28	min	9.90	5.00	7.40		0.05		0.22	0.63	0°	FR28
	max	10.50	5.60	8.20	2.13	0.25	0.65	0.38	1.03	8°	

Dimension: mm, coplanarity < 0,1 mm, original dimension: inch

## **17. Disclaimer**

Devices sold by Melexis are covered by the warranty and patent indemnification provisions appearing in its Term of Sale. Melexis makes no warranty, express, statutory, implied, or by description regarding the information set forth herein or regarding the freedom of the described devices from patent infringement. Melexis reserves the right to change specifications and prices at any time and without notice. Therefore, prior to designing this product into a system, it is necessary to check with Melexis for current information. This product is intended for use in normal commercial applications. Applications requiring extended temperature range, unusual environmental requirements, or high reliability applications, such as military, medical life-support or life-sustaining equipment are specifically not recommended without additional processing by Melexis for each application.

The information furnished by Melexis is believed to be correct and accurate. However, Melexis shall not be liable to recipient or any third party for any damages, including but not limited to personal injury, property damage, loss of profits, loss of use, interrupt of business or indirect, special incidental or consequential damages, of any kind, in connection with or arising out of the furnishing, performance or use of the technical data herein. No obligation or liability to recipient or any third party shall arise or flow out of Melexis' rendering of technical or other services.

**Important notice:** The use of Melexis products or software to create products or systems that may infringe the Intellectual Property rights of third parties is entirely the responsibility of the customer and Melexis accepts no liability for such infringements.

© 2005 Melexis NV. All rights reserved.

For the latest version of this document, go to our website at:

**[www.melexis.com](http://www.melexis.com)**

Or for additional information contact Melexis Direct:

Europe and Japan:

Phone: +32 13 67 04 95

E-mail: [sales\\_europe@melexis.com](mailto:sales_europe@melexis.com)

All other locations:

Phone: +1 603 223 2362

E-mail: [sales\\_usa@melexis.com](mailto:sales_usa@melexis.com)

ISO/TS 16949 and ISO14001 Certified